

H cores

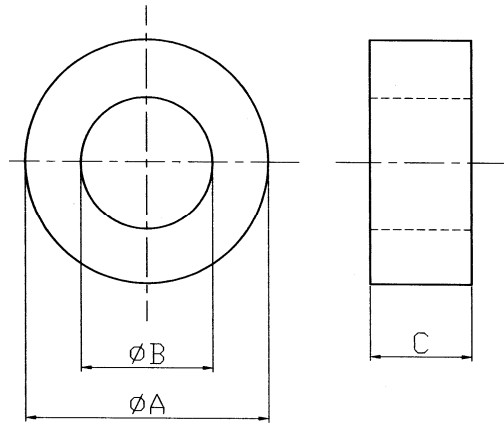

CORE SETS

CORE DIMENSIONS (mm)

Spray paint	Dimensions (mm)		
	ϕA	ϕB	C
	3.5 ± 0.3	1.3 ± 0.3	9.0 ± 0.4

Effective core parameters

SYMBOL	PARAMETER	VALUE	UNIT
Ve	effective volume	74.61	mm ³
le	effective length	8.18	mm
Ae	effective area	9.12	mm ²
Wt	mass of core set	≈ 0.38	g

Characteristic

Grade	AL (nH/N ²)	Z (Ω)
		f=100kHz U=0.01V N=10Ts, $\Phi 0.1$ mm
DN150H	$1800 \pm 25\%$	30 min