

1.尺寸 DIMENSION(mm)

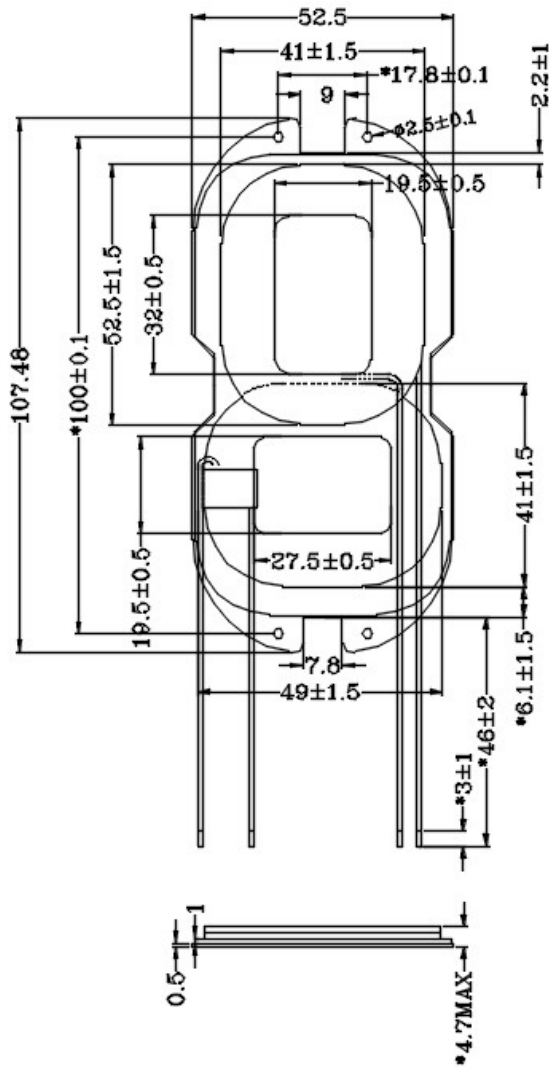

2.绕线参数 WINDING DETAILS

序号 NO.	线规格 Material	圈数 Turns	尾线是否交叉 INTERSECT
1	0.08*105P 丝包线 SILK-COVERED WIRE	9Ts	是 YES
2	0.08*105P 丝包线 SILK-COVERED WIRE	9Ts	是 YES



技术参数

DM-TS9352B-11

technical parameter

3. 电气特性

100KHz/1Vrms , 温度 TEMPERATURE:25±10°C, 湿度 RELATIVE HUMIDITY:65±20%

序号 NO.	参数 ITEM	上线圈 COIL 1	下线圈 COIL 2
1	Ls	7.4±10% uH	7.0±10% uH
2	DCR	55 mΩ MAX	55 mΩ MAX
3	Q	55 MIN	55 MIN