

1、电气性能 Electrical Characteristics

序号 NO.	项目 Item	测试条件 Measuring condition	规格 Specification
1	额定电压 Rated voltage	加在端子两端的电压 Voltage applied to both ends of the terminal	DC3.8V
2	额定转速 Rated speed	在额定电压及负荷下测试 At Rated voltage and rated load	8000rpm min
3	额定电流 Rated current	在额定电压及负荷下测试 At Rated voltage and rated load	100 mA MAX
4	堵转电流 Stall current	额定电压下锁定电机轴条件下测试 At rated voltage and shaft locked	200 mA MAX
5	起动电压 Starting voltage	在额定负载下转子任意位置 At rated load any position of rotor	DC 2.3V MAX
6	电枢电阻 Terminal resistance	端子阻抗 Measure between terminals	1 Phase contact: 50Ω±15%
			2 Phase serial: 80Ω±15%
			2 Phase parallel: 35Ω±15%
7	绝缘电阻 Insulation resistance	100V 直流电压下导线与机壳之间 Test between lead wire and case at DC 100V	10MΩ MIN
8	绝缘电压 Insulation voltage	在导线与马达机身之间提供 DC50V 电压一分钟 DC50V between lead wire and motor case for one minute	No destruction occurs
9	机械噪音 Mechanical noise	额定电压下, 背景噪声≤25 dB(A),电机固定在测试夹具上,拾音器沿轴向正对电机平面, 距离 10 cm。 At rated voltage, Back ground noise: 25 dB(A) Max, Fix the motor in a test jig. Microphone is faced to the motor and recedes by 10cm	50dB(A)MAX
5-10	振动量 Vibration swing		≥1.5G

2、产品外形图 Product Drawing

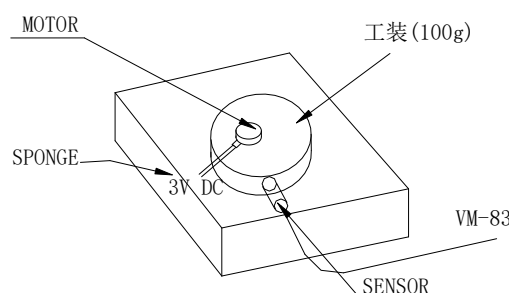
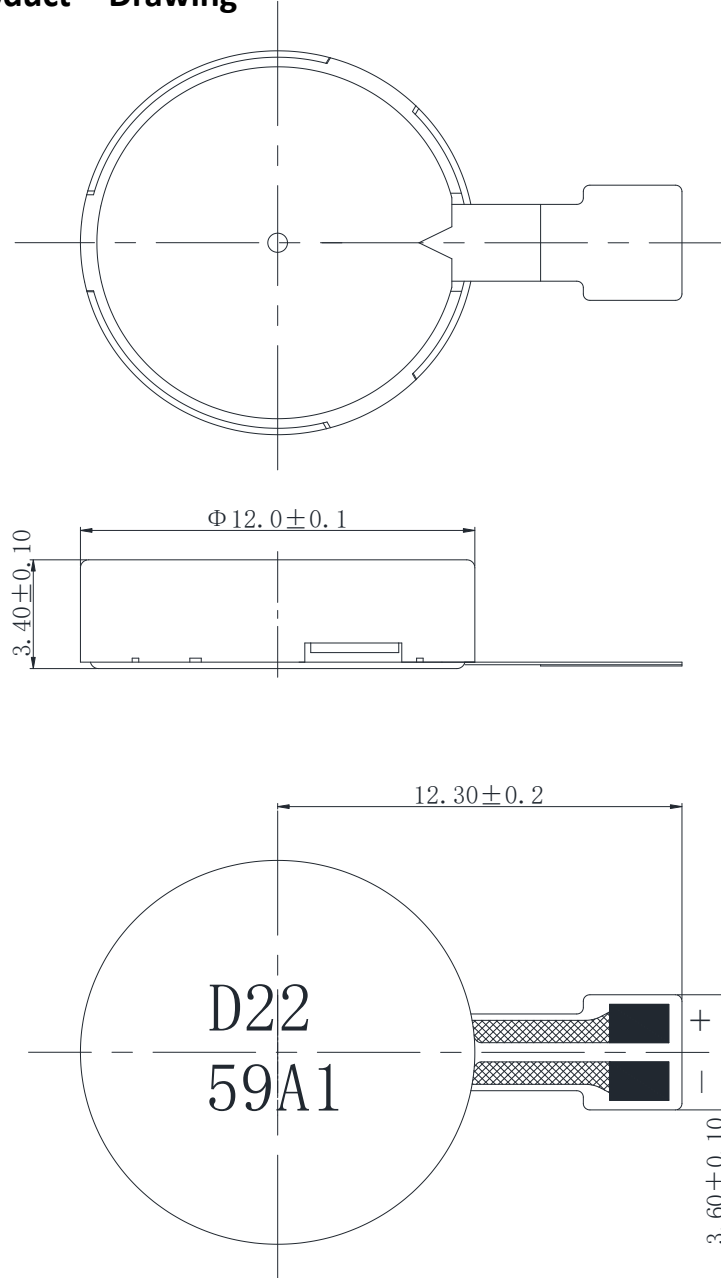

技术要求 (Technical requirement):

1. 未注尺寸公差为 $\pm 0.2\text{mm}$ 。(Unnoted dimensional tolerances are $\pm 0.2\text{mm}$)
2. 喷码方式如下示例: (Sprts the code way as follows the example)
 10月、11月、12月分别用A、B、C表示。(Oct. Nov. and Dec. are represented by ABC)
 第10日开始用A-Z表示。(Day 10 begins with A~Z)
 字母O, Q, I, U不做使用 (The letters O, Q, I, and U are not used)

公司代码 D 22 年 (YEAR)

(Company code) 5 9 A 1

月 日 班组 线别 (The line does not)

Month Day Team