

CORE SETS

Effective core parameters

SYMBOL	PARAMETER	VALUE	UNIT
$\Sigma (1/A)$	core factor (C_1)	1.72	mm^{-1}
V_e	effective volume	507.40	mm^3
l_e	effective length	29.50	mm
A_e	effective area	17.20	mm^2
W_t	mass of core	≈ 2.7	g

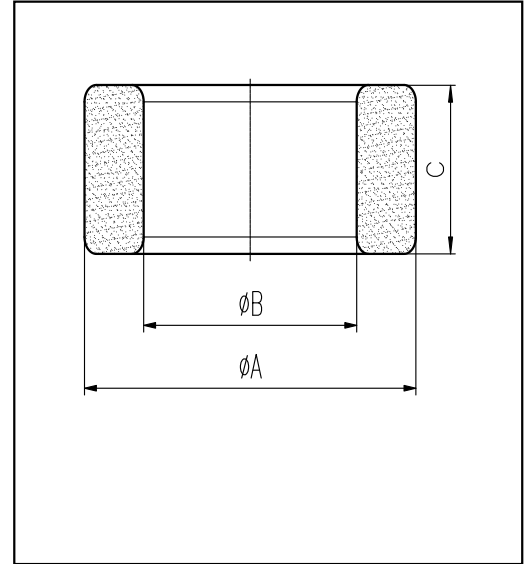

尺寸	A	B	C
Coat			
Uncoat	12.7 ± 0.4	7.14 ± 0.3	6.35 ± 0.3
Coated	13.5max	6.44min	7.05max

Note: With grass green epoxy coating

Characteristic

GRADE	AL (nH/N ²)	B (mT)	CORE LOSS (W)
		f=10kHz U=0.25V	H=250A/m f=25kHz T=100°C
DMR40	$1600 \pm 25\%$	≥ 315	≤ 0.351