

### H cores

#### CORE SETS

##### Effective core parameters

SYMBOL	PARAMETER	VALUE	UNIT
$\Sigma (1/A)$	core factor ( $C_1$ )	0.65	$\text{mm}^{-1}$
$V_e$	effective volume	31680.00	$\text{mm}^3$
$l_e$	effective length	144.00	mm
$A_e$	effective area	220.00	$\text{mm}^2$
$W_t$	mass of core	$\approx 165.5$	g

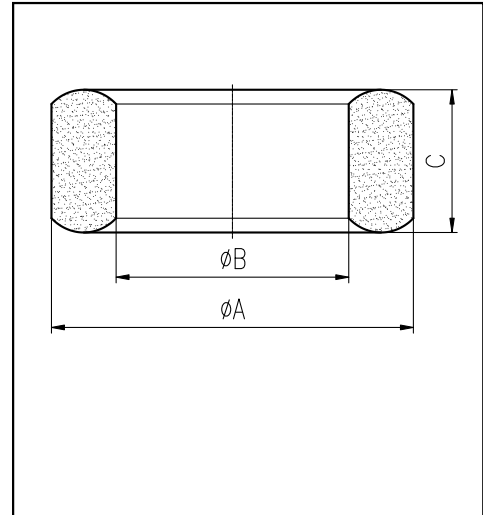

尺寸	A	B	C
Coat			
Uncoat	$60.0 \pm 1.5$	$36.0 \pm 1.2$	$20.0 \pm 0.5$
Coated	62.2max	34.2min	21.2max

Note: With grass green epoxy coating

#### Characteristic

GRADE	AL ( $\text{nH}/\text{N}^2$ )	B (mT)	CORE LOSS (W)
	$f=10\text{kHz}$ $U=0.25\text{V}$	$H=250\text{A/m}$ $f=25\text{kHz}$ $T=100^\circ\text{C}$	$f=100\text{kHz}$ $B=200\text{mT}$ $T=100^\circ\text{C}$
DMR40	$4600 \pm 25\%$	$\geq 315$	$\leq 21.5$
DMR44	$4600 \pm 25\%$	$\geq 315$	$\leq 19.9$
DMR95	$6700 \pm 25\%$	$\geq 315$	$\leq 19.0$