

H cores

CORE SETS

Effective core parameters

SYMBOL	PARAMETER	VALUE	UNIT
$\Sigma (1/A)$	core factor (C_1)	3.99	mm^{-1}
V_e	effective volume	67.40	mm^3
l_e	effective length	16.40	mm
A_e	effective area	4.11	mm^2
W_t	mass of core	≈ 0.4	g

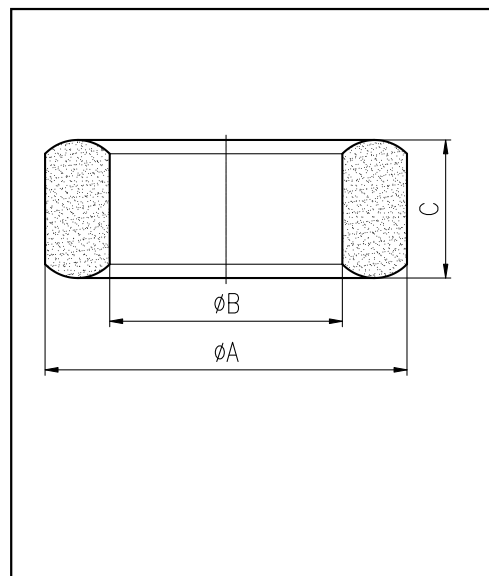

尺寸	A	B	C
Coat			
Uncoat	7 ± 0.4	4 ± 0.3	3 ± 0.3
Coated	7.7max	3.4min	3.6max

Note: With grass green epoxy coating

Characteristic

GRADE	AL (nH/N^2)	B (mT)	CORE LOSS (W)
	$f=10\text{kHz}$ $U=0.25\text{V}$	$H=250\text{A/m}$ $f=25\text{kHz}$ $T=100^\circ\text{C}$	$f=100\text{kHz}$ $B=200\text{mT}$ $T=100^\circ\text{C}$
DMR40	$770 \pm 25\%$	—	—
DMR44	$770 \pm 25\%$	—	—