

H cores

CORE SETS

Effective core parameters

SYMBOL	PARAMETER	VALUE	UNIT
$\Sigma (1/A)$	core factor (C_1)	0.56	mm^{-1}
V_e	effective volume	82560.00	mm^3
l_e	effective length	215.00	mm
A_e	effective area	384.00	mm^2
W_t	mass of core	≈ 416.6	g

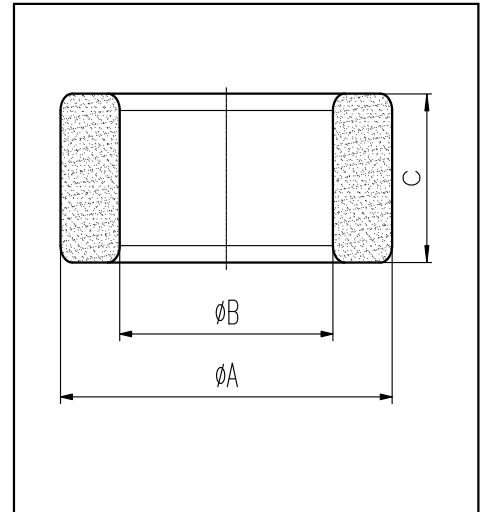

尺寸	A	B	C
Coat			
Uncoat	$85.7^{+2.0}_{-1.0}$	55.5 ± 1.0	25.4 ± 1.0
Coated	88.5max	53.9min	27.0max

Note: With grass green epoxy coating

Characteristic

GRADE	AL (nH/N^2)	B (mT)	CORE LOSS (W)
		f=10kHz U=0.25V	H=250A/m f=25kHz T=100°C
DMR40	$5100 \pm 25\%$	≥ 320	≤ 54.16