

H cores

CORE SETS

Effective core parameters

SYMBOL	PARAMETER	VALUE	UNIT
$\Sigma (1/A)$	core factor (C_1)	1.88	mm^{-1}
V_e	effective volume	227.70	mm^3
l_e	effective length	20.70	mm
A_e	effective area	11.00	mm^2
W_t	mass of core	≈ 1.23	g

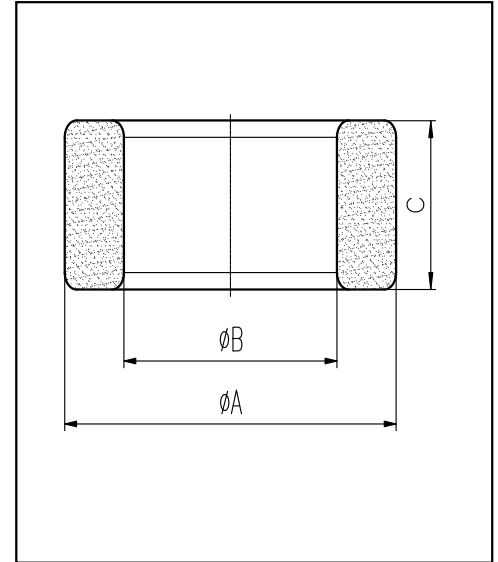

尺寸 Coat	A	B	C
Uncoat	9.53 ± 0.25	4.75 ± 0.25	4.78 ± 0.25
Coated	10.18max	4.10min	5.43max

Note: With grass green epoxy coating

Characteristic

GRADE	AL (nH/N^2)	B (mT)	CORE LOSS (W)
		f=10kHz U=0.25V	H=250A/m f=25kHz T=100°C
DMR40	$1400 \pm 25\%$	—	—